

# TECHNICAL DATAS SHEET

## SP 1200 B-C

### MODEL :

Brick version : 1200 B  
Refractory concrete : 1200 C

### MATERIALS :

Refractory brick  
Refractory concrete  
Reinforced with metal fibres

### PARTS :

Hearthstone : Stone + little bricks  
Oven arch : 7 Parts + 1 frame  
The arch

### CARACTERISTICS

Cooking chamber : 12.16 sq ft  
Weight : 2000 lbs for refractory concrete model, 2400 Kg for brick model

### POWER USED :

Pre firing : 9 Kg wood/Hour (20 % dampness) = 36 KW/H  
Cooking with the door opened : 4.5 Kg wood/Hour (20 % dampness) = 18 KW/H

Power going through the sides with the advised insulation : 1KW/H  
Radiation power (through the door) : 1.9 KW/H

Fresh air consumption : 290 m3/Hour at 20 ° C  
Minimal smoke pipe : Height 3 m- Part 240 cm<sup>2</sup>- diameter 200 mm

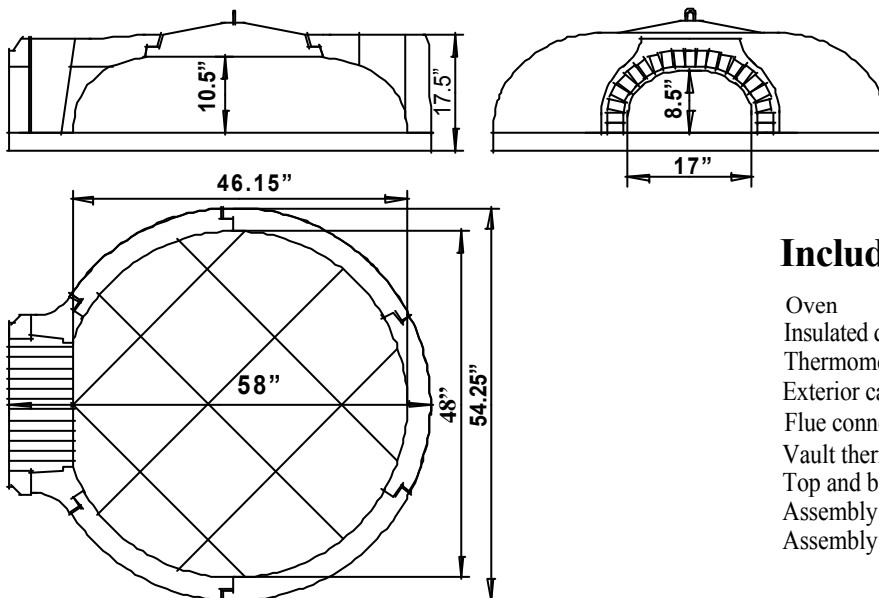
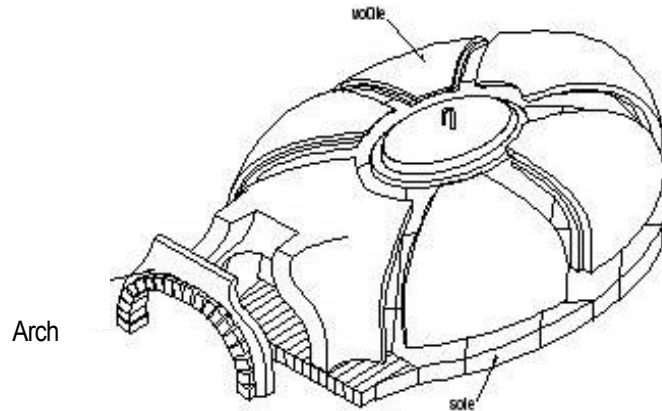

### Included in the kit:

- Oven
- Insulated door
- Thermometer
- Exterior cast iron door
- Flue connector with shut-off valve
- Vault thermometer
- Top and bottom insulation
- Assembly mortar
- Assembly instructions

Four "Grand Mere" for  
Bread Stone Ovens, LLC - 2014  
11140 Petal Street, Suite 250  
Dallas, TX 75238